

### SINGLE DEFLECTION SUPPLY (SPG-V SHOWN)

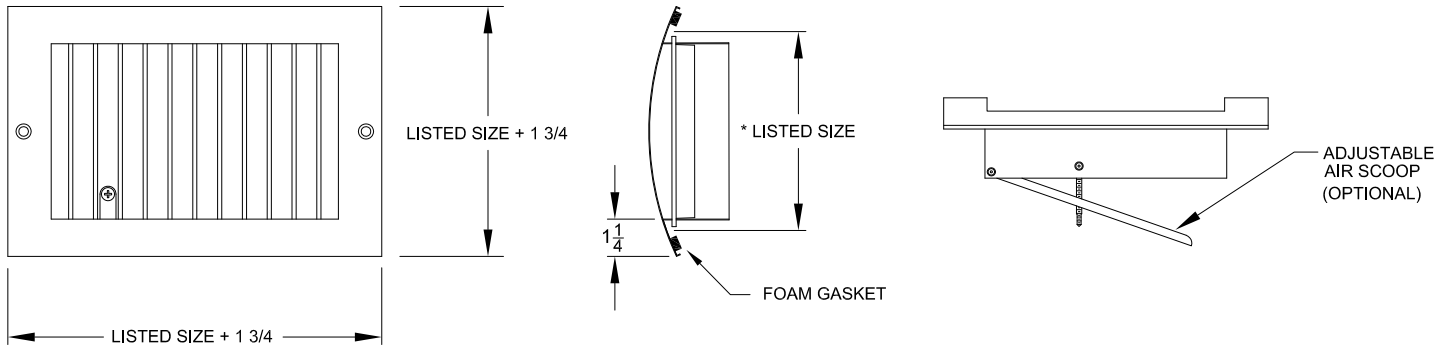

- SPG-H HORIZONTAL BLADES
- SPG-V VERTICAL BLADES

\*LISTED SIZE= DUCT SIZE AND ROUGH OPENING SIZE

### DOUBLE DEFLECTION SUPPLY (SPG-VH SHOWN)

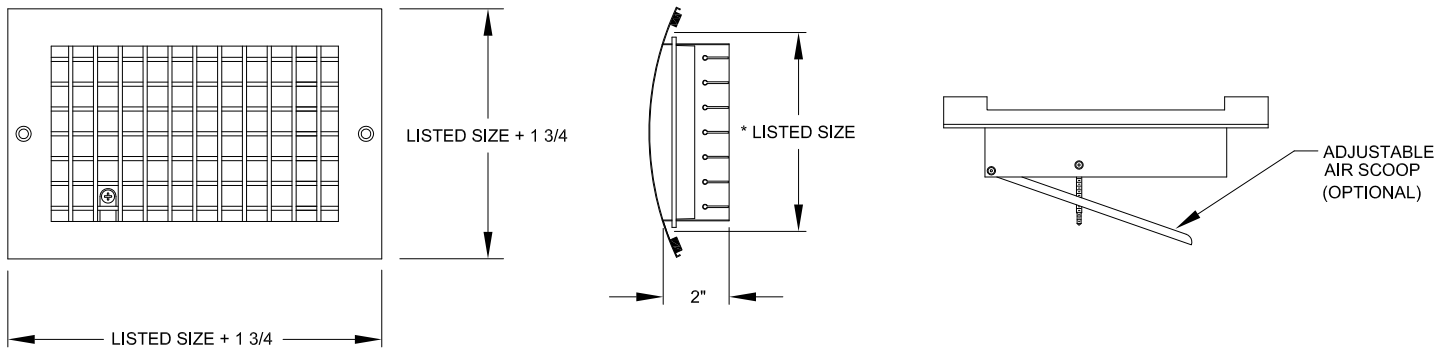

- SPG-HV HORIZONTAL FRONT BLADES
- SPG-VH VERTICAL FRONT BLADES

#### FEATURES

- 24 GA. GALVANIZED STEEL CONSTRUCTION
- TRUE FORM CURVED FACE
- MILL FINISH GALVANIZED STANDARD
- POWDER COAT FINISHES AVAILABLE
- INDIVIDUALLY ADJUSTABLE BLADES, 3/4" SPACING
- COUNTERSUNK SCREW HOLES ARE STANDARD
- INSTALLED FULL PERIMETER FOAM GASKET SEAL

#### OPTIONS (SPECIFY)

- \_\_\_\_\_ MODEL (EX: SPG-VH)
- \_\_\_\_\_ LISTED SIZE (EX: 12X6) 2" INCREMENTS TO MAX. 48"
- \_\_\_\_\_ DUCT DIAMETER (EX: 18)
- ADJUSTABLE AIR SCOOP
- STANDARD MILL FINISH GALVANIZED
- POWDER COAT WHITE FINISH
- POWDER COAT SILVER FINISH
- POWDER COAT BLACK FINISH
- POWDER COAT PRIMER FINISH

HEIGHT	3	4	6	8	10	12
DUCT DIAMETER MIN./MAX.	6 / 36	8 / 36	10 / 36	12 / 36	14 / 36	16 / 36
WIDTH MIN./MAX.	10 / 48		14 / 48	16 / 48	18 / 48	

WIDTHS ARE AVAILABLE IN 2" INCREMENTS FROM 10 TO 48".

STANDARD INDUSTRY TOLERANCES APPLY. SPECIFICATIONS ARE SUBJECT TO CHANGE WITHOUT NOTICE.

JOB NAME: \_\_\_\_\_  
 LOCATION: \_\_\_\_\_  
 ARCHITECT: \_\_\_\_\_  
 ENGINEER: \_\_\_\_\_  
 CONTRACTOR: \_\_\_\_\_

## MODEL SPG SPIRAL DUCT GRILLES

DRAWN BY: CAN      DATE: 8-30-16      DWG. NO. SPG