

AIR DISTRIBUTION SUBMITTAL

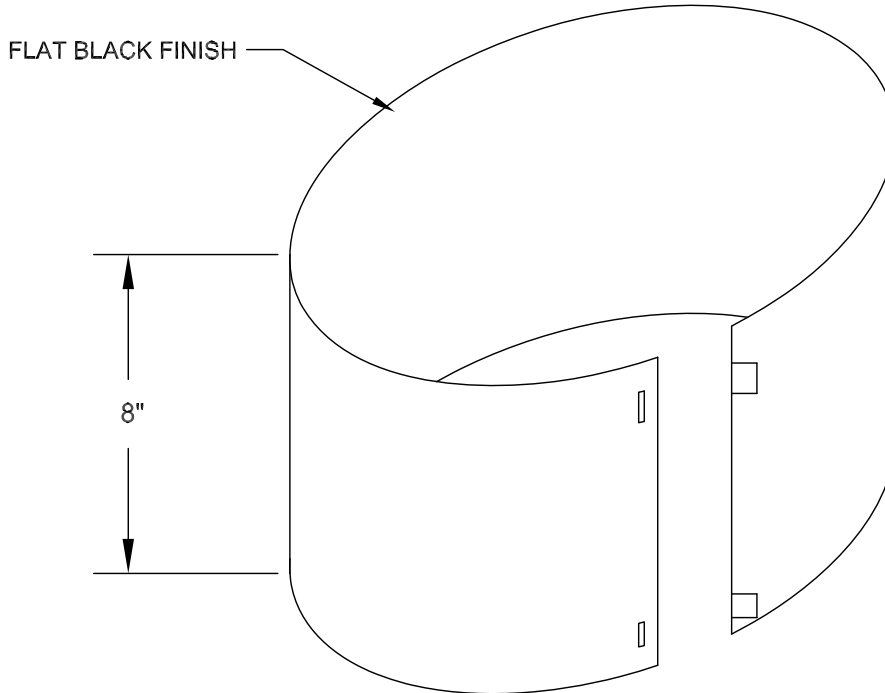

LIGHT SHIELD (8" HEIGHT)
USED FOR OPEN RETURN APPLICATIONS
TO PROVIDE VISUAL BLOCK TO CEILING
SPACE

FEATURES

- MATERIAL: 24 GAUGE STEEL
- FLAT BLACK FINISH
- FINISHED DIAMETER OF NOMINAL - 3/16"
- AVAILABLE IN 6, 8, 10, 12, 14, 15 & 16" DIAMETERS
- PRE-ROLLED WITH TAB & SLOT FIELD-ASSEMBLY
ALLOWS NESTING FOR BULK PACKAGING

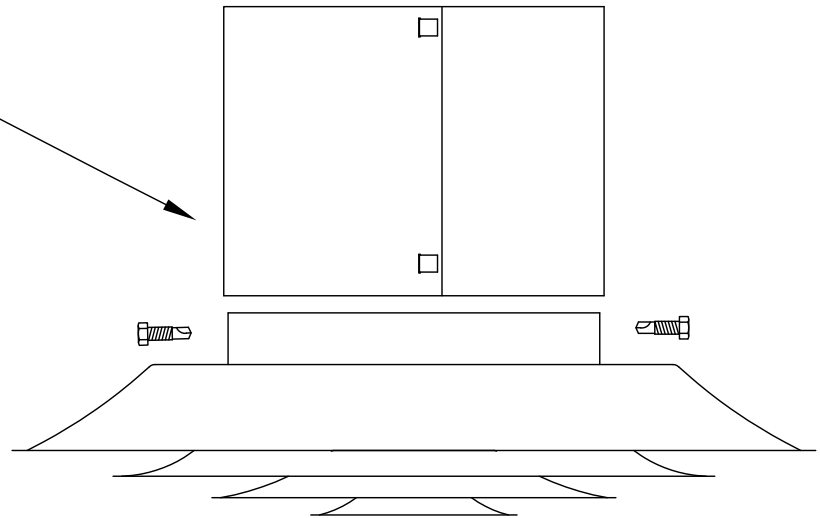

OPTIONS (SPECIFY)

___ NOMINAL SIZE (6, 8, 10, 12, 14, 15, 16)

STANDARD INDUSTRY TOLERANCES APPLY. SPECIFICATIONS
ARE SUBJECT TO CHANGE WITHOUT NOTICE.

JOB NAME: _____
LOCATION: _____
ARCHITECT: _____
ENGINEER: _____
CONTRACTOR: _____

MODEL RLS ROUND LIGHT SHIELD

DRAWN BY
RBJ

DATE
7-26-11

DWG. NO.
RLS

P.O. BOX 250
ALBION, IOWA 50005
PH. (641) 488-2211 FAX (641) 488-2796
www.raymon-hvac.com



RAYMON
DONCO AIR DISTRIBUTION EQUIPMENT