

# AIR DISTRIBUTION SUBMITTAL

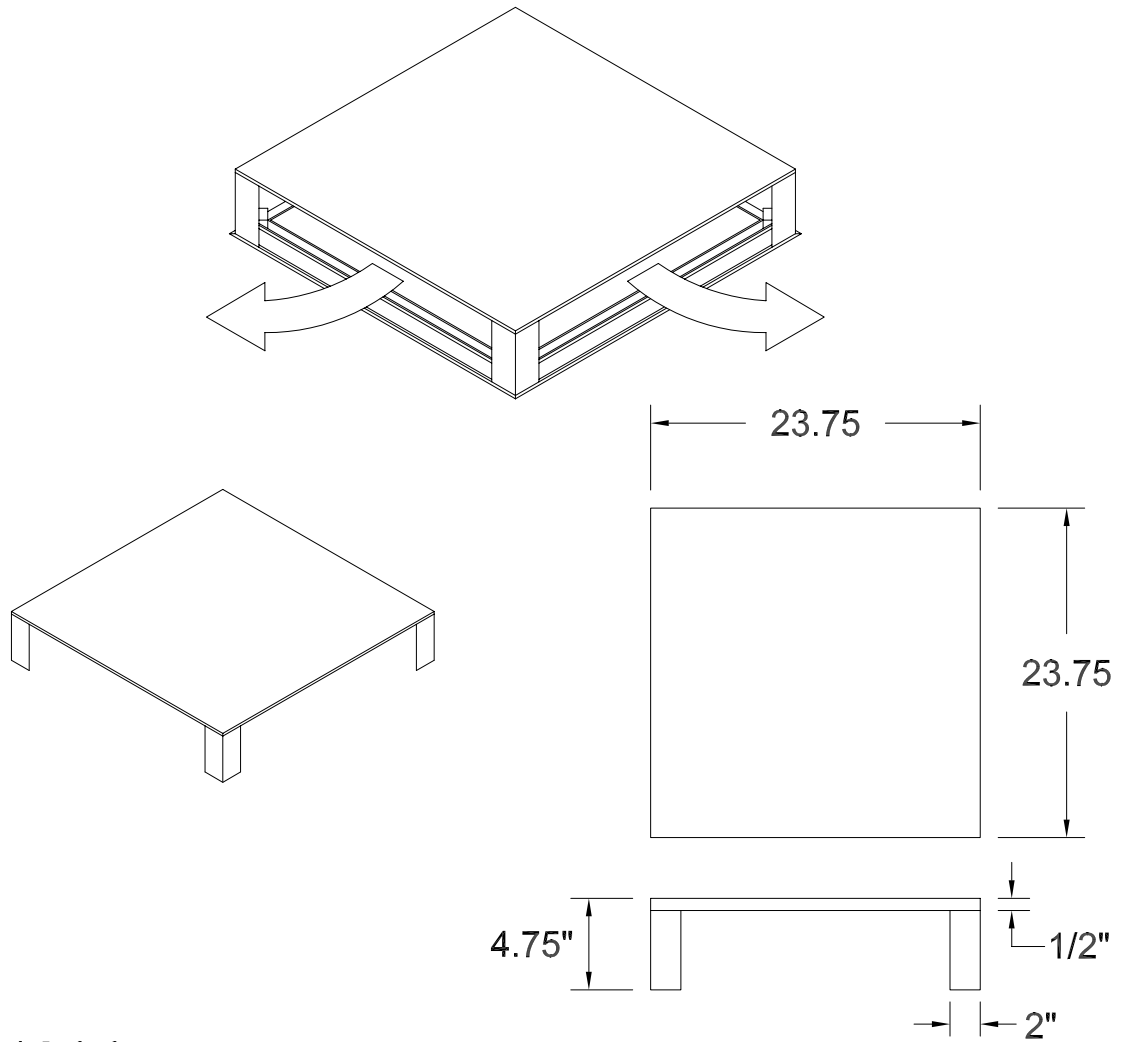

## FEATURES

- 24 GA. STEEL CONSTRUCTION
- INTERNAL SURFACES PAINTED FLAT BLACK

STANDARD INDUSTRY TOLERANCES APPLY. SPECIFICATIONS ARE SUBJECT TO CHANGE WITHOUT NOTICE.

JOB NAME: \_\_\_\_\_  
LOCATION: \_\_\_\_\_  
ARCHITECT: \_\_\_\_\_  
ENGINEER: \_\_\_\_\_  
CONTRACTOR: \_\_\_\_\_

## NOMINAL 24X24 LIGHT SHIELDS

DRAWN BY  
RBJ

DATE  
12-19-06

DWG. NO.  
LS

P.O. BOX 250  
ALBION, IOWA 50005  
PH. (641) 488-2211 FAX (641) 488-2796  
www.raymon-hvac.com



**RAYMON**  
DONCO AIR DISTRIBUTION EQUIPMENT