

FEATURES

- ALL WELDED ALUMINUM CONSTRUCTION
- 1/8" WIDE FIXED POSITION BARS AT ZERO OR 15 DEG. DEFLECTION
- BAR CENTERLINE SPACINGS: 1/4" PENCIL-PROOF OR 1/2"
- END TERMINATIONS ARE MITERED
- WELDED CORE IS STANDARD. REMOVABLE CORE IS OPTIONAL.
- MINIMUM DUCT WIDTH IS 1 1/2", MAXIMUM DUCT WIDTH IS 8".
- MAXIMUM LENGTH PER SECTION IS 96"
- ALIGNMENT STRIPS PROVIDED FOR CONTINUOUS APPLICATIONS
- CLEAR ANODIZED FINISH STANDARD
- COLORED ANODIZED FINISHES AVAILABLE. CONTACT FACTORY.
- MITERED CUTS AND CORNERS AVAILABLE. CONTACT FACTORY.

OPTIONS (SPECIFY)

- DUCT LENGTH
- DUCT WIDTH
- BAR SPACING 1/4" 1/2"
- DEFLECTION 0 DEG. 15 DEG.
- REMOVABLE CORE
- ANODIZED SPECIAL COLOR
- SCREW HOLES (STANDARD)
- NO SCREW HOLES
- OPPOSED BLADE DAMPER (ORDER SEPARATELY)

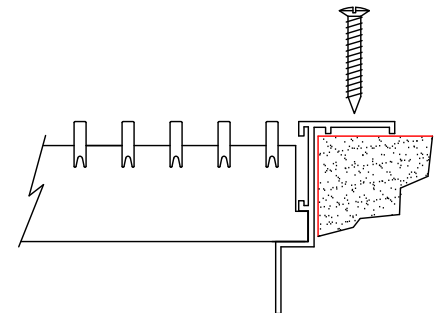

SCREW FASTENING
COUNTERSUNK HOLES AND SCREWS PROVIDED

STANDARD INDUSTRY TOLERANCES APPLY. SPECIFICATIONS ARE SUBJECT TO CHANGE WITHOUT NOTICE.

JOB NAME: _____
 LOCATION: _____
 ARCHITECT: _____
 ENGINEER: _____
 CONTRACTOR: _____

DBG-400 SERIES FLOOR GRILLE

DRAWN BY: JLH DATE: 4-16-12 DWG. NO. DBG-400

RAYMON P.O. BOX 250 ALBION, IOWA 50005 www.raymon-hvac.com